

Product Diagram & Installation Details

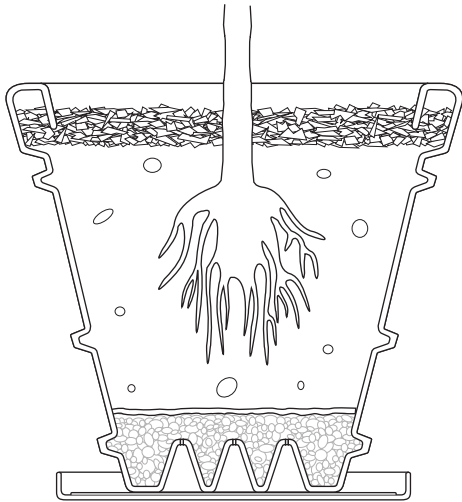

Product Specifications

Material: High Density Polyethylene

Weight: 20 lbs.

Capacity: 34 Gallons

Height: Top x Bottom x Height
29" x 15.5" x 24"

Accessories: Round Planter Trays VPS-5
Diameter x Height
19" x 2"

Installation Instructions

- Suggestion:**
1. Fill with stone one inch above drainage riser
 2. It is recommended to insert a weed barrier between soil and rock
 3. Place foliage in planter and backfill with soil
 4. For a complete finish add decorative stone or mulch

Benefits: Valley View's Venus Planters are available in wide range of color palettes of solid and granite designs.

Guarantee: Valley View Industries provides a twenty year guarantee against cracking or decomposing.



Toll Free Distribution Network: 1-800-323-9369

☐ ☐ ☐ **Fax:** 1-800-323-3262

Planter Profile

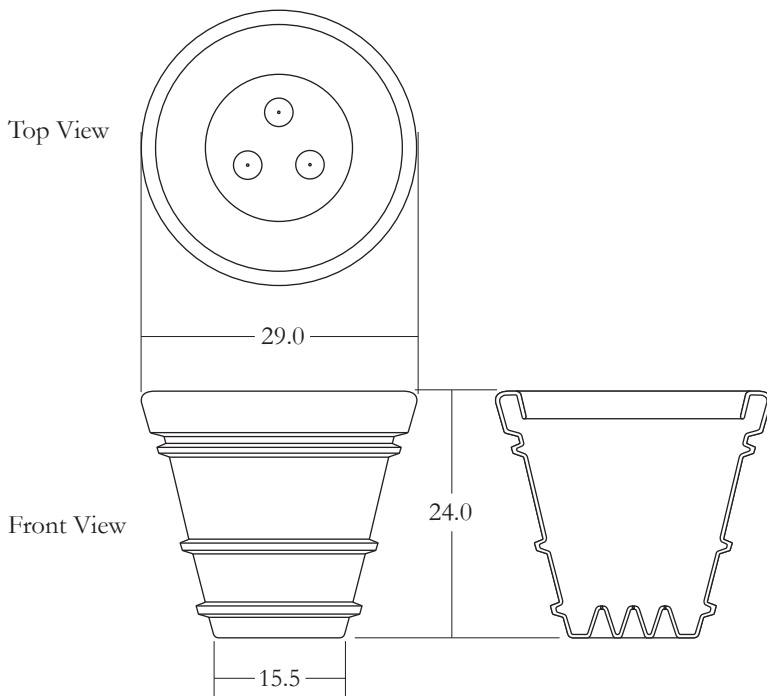

Accessories: